

DEPARTMENT OF METALLURGY AND MATERIALS ENGINEERING
Indian Institute of Engineering Science and Technology, Shibpur
Howrah-711 103

Enquiry No. 01/MET/SK/CPDA/IEST/2016-17

Date: 23/11/2016

To,
All the Enlisted Suppliers/Dealers/Manufacturers

Sealed quotations are invited for supply of Tungsten Carbide tool with pin under CPDA Account of Dr. Sukumar Kundu, Assistant Professor, Dept. of Metallurgy and Materials Engineering. The sealed quotations should be addressed to the Head of the Department indicating enquiry no. with date on the top of the sealed envelope. The sealed quotations should be submitted at the office of the department on any working day up to 06/12/2016 till 5.00 P.M.

Specification:

1. Tungsten Carbide tool with pin length of 2.7mm, 2.6mm and 2.5 mm required as per the diagram - 5 nos. each



(Dr. S. K. Ghosh)
Professor & Head
Dr. Swarup Kr. Ghosh
Professor & Head
Dept. Of Met. & Mat. Engg.
Indian Institute of Engineering
Science and Technology, Shibpur
Howrah - 711 103

Copy forwarded for information to:

Institute Website, IEST, Shibpur, Howrah-711103

For details the vendors may contact Dr. Sukumar Kundu (Mobile No. 8334043609) during working hours.

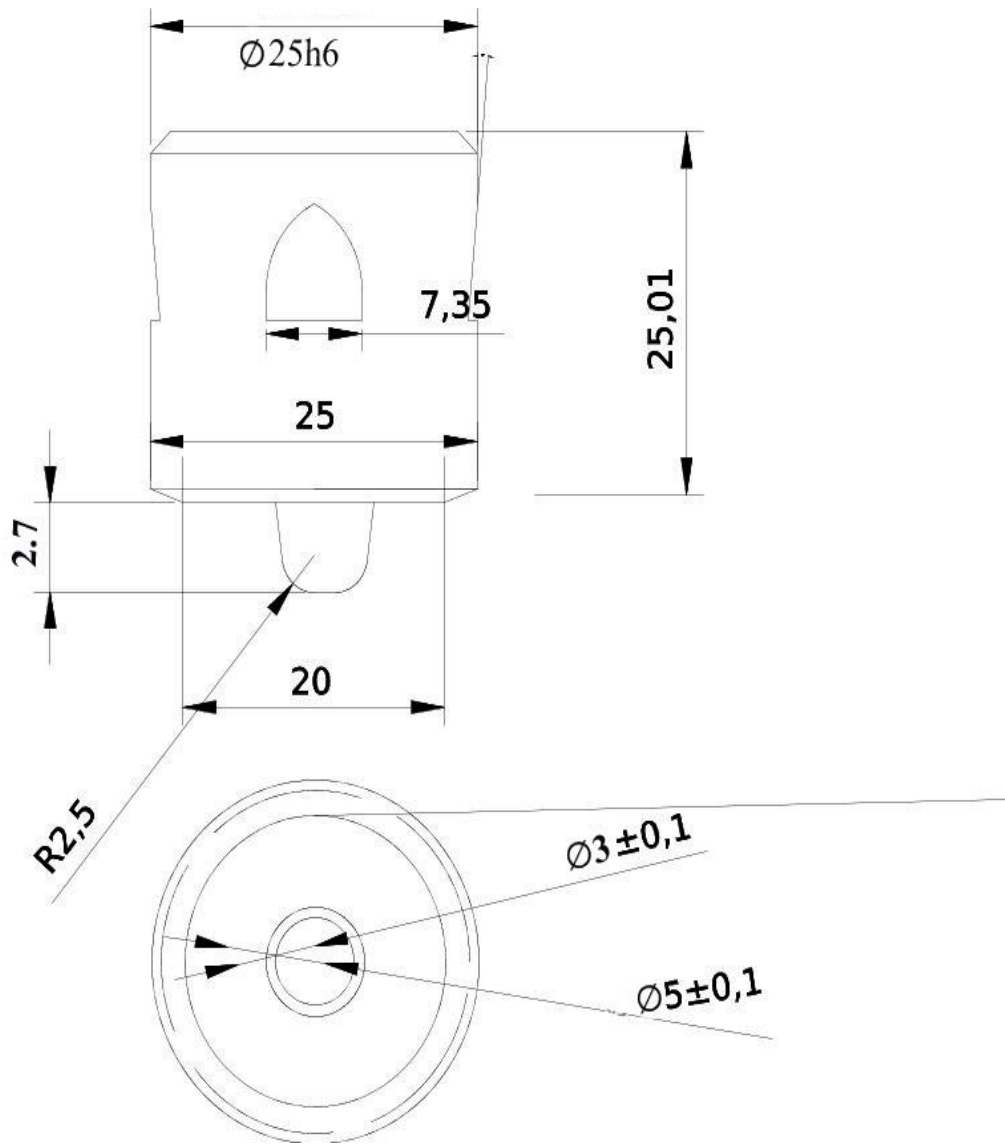
1. Tungsten Carbide tool with pin length of 2.7 mm required as per the diagram
- 5 nos.



2. Tungsten Carbide tool with pin length of 2.6 mm required as per the diagram
- 5 nos.

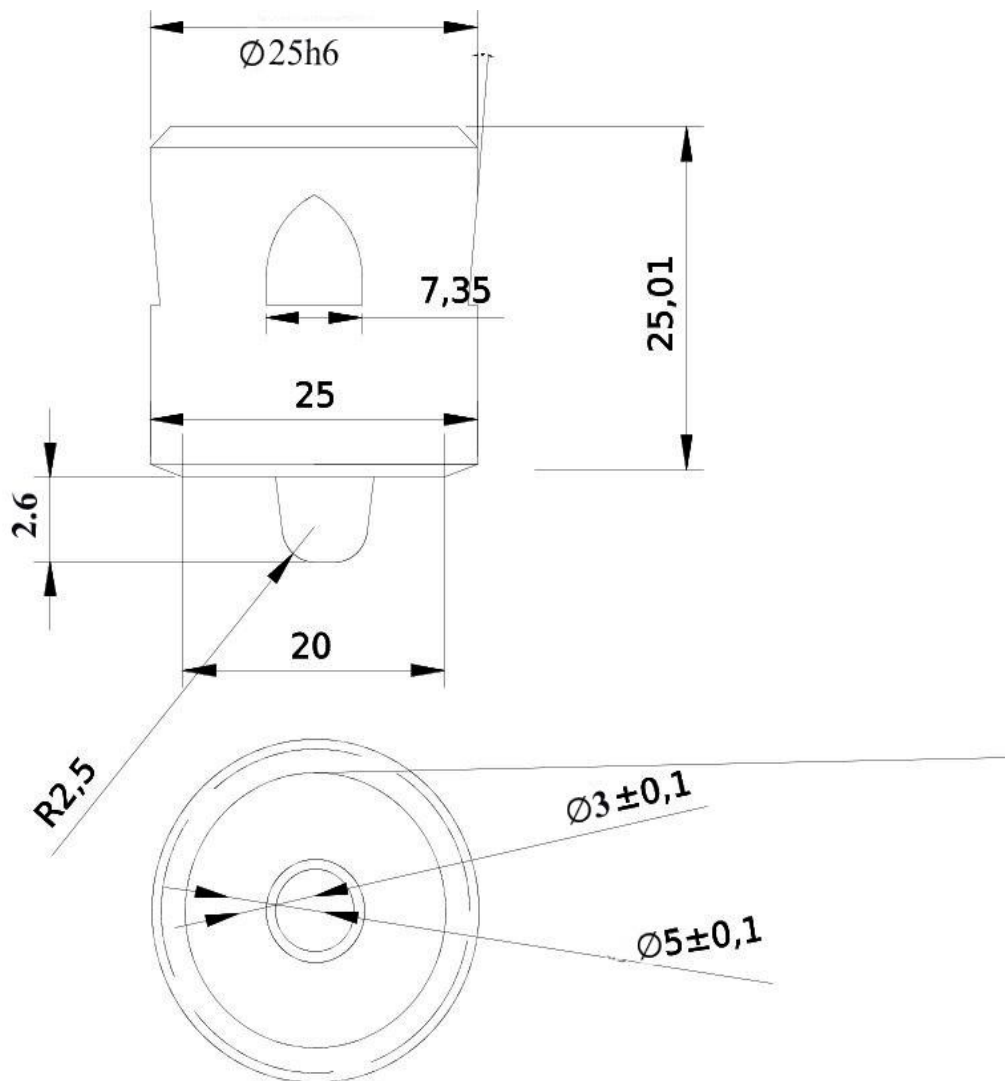

3. Tungsten Carbide tool with pin length of 2.5 mm required as per the diagram
- 5 nos.

