

IEST, Shibpur
Howrah – 711103
Advt. No JL/D(AA)/16/33 dated 25.07.2016

TENDER

Sealed quotations are invited for the Rate – contract of furniture items. Details are available in website: www.iests.ac.in. **Last date of submission of bid is 16th August 2016.**

Dean Administration

INDIAN INSTITUTE OF ENGINEERING SCIENCE AND TECHNOLOGY (IEST) SHIBPUR

P. O. Botanic Garden, Howrah – 711103.

Tender Notice

Indian Institute of Engineering Science & Technology, Shibpur, Howrah invites the sealed quotation/ tender (item wise) for Rate – contract of branded furniture from original manufacturers or their authorized dealers/distributors / Kendriya Bhandar (under aegis of Govt. of India) for various furniture items for the period August 2016 – August 2017.

Reference Tender Advt. No. : Advt. No JL/D(AA)/16/33 dated 25.07.2016

Subject. : Tender Quotation for various Furniture items for the period August 2016 – August 2017 on rate Contract basis.

Submission of quotation: Quotation along with required documents to be submitted to the letter box of Dr Sudipta Mukhopadhyay, Prof-in-charge of Furniture, Department of Mining Engineering, IEST, Shibpur, P.O. Botanic Garden, Howrah-711103, West Bengal, India (kept at 1st floor of the Mining Engineering Deptt., IEST, Shibpur). Last date of submission of bid/tender is 16th August 2016 upto 5.00 p.m.. During bid submission, Tender advt. No. must be mentioned on the top of the outer envelope.

Section -1: General Terms & conditions and important instructions for Bidders

- 1. Quotation should be addressed to the Director, Indian Institute of Engineering Science & Technology Shibpur, Howrah – 711103, under sealed cover failing which the tender shall be rejected. Terms and conditions for supply should invariably be indicated otherwise would be taken on its face value. Without the required valid documents, quotation will be rejected and any communication in this regard will not be entertained.**
- 2. The bidder should give rates, showing taxes, if any, and levies, packing forwarding and insurance charges separately giving full breakup details. THE INSTITUTE IS NOT AUTHORIZED TO ISSUE „C/D FORMS“.**
- 3. THIS QUOTATION OFFER/ RATE CONTRACT IS NON-TRANSFERABLE.**
- 4. The quoted rates should be kept opened/valid minimum for a period from August 2016 to August 2017.**
- 5. The bidder shall clarify/state whether he/they are manufacturer of the items or authorized dealer/distributor of mentioned brand.**

6. In case of Dealers/Distributors, an authorization letter from the original manufacturer w.r.t. this tender submission must have to be furnished, without which their quotation will not be considered.

7. Bidders submitting quotation would be considered to have considered and accepted all the terms and conditions. No inquiries verbal or written shall be entertained in respect of acceptance or rejection of the offer.

8. OFFER SHALL BE REJECTED IF THE COPY OF LATEST VAT/ CST & PAN REGISTRATION CERTIFICATE IS NOT FURNISHED. Sales tax/VAT and other statutory levies should be shown separately and should not be included in the basic price otherwise it will not be considered.

9. Bidder should submit a DD of Rs. 500/- (Five Hundred only) as tender fee, in favour of "Registrar, IEST, Shibpur"with the bid documents, without which their quotation will not be considered.

10. Bidder shall furnish an undertaking for providing Comprehensive onsite warranty for any manufacturing defect for a period as mentioned against each furniture item from the date of supply/installation on their letter head, failing which, their offer will not be considered.

11. Bidder shall furnish **a non-blacklisting affidavit on non-judicial stamp paper of Rs.10/- duly attested by the Notary** that there is no vigilance/CBI case pending against the firm/supplier and the firm has not been blacklisted in the past by any government/Private institution.

12. Status of the bidder should be clear by submitting the required documents.

13. All bidders should have Fax facility and telephone number in their office and the same may be indicated on their letterhead in the tender. Any change in such numbers should be informed to the concerned immediately.

14. Quotation by Tele-fax/telegram/fax/e-mail will not be accepted.

15.The bidder is also required to submit performance report(s) from other similar Organizations where the firm is registered for supply of furniture Items for the last three years. The firm should also submit list of organizations where the furniture has been supplied in the last three years along with complete details of items supplied, otherwise, quotation shall be summarily rejected.

16. SELECTION WILL BE MADE PURELY ON ESSENTIAL TECHNICAL DOCUMENTS. The IESTS authority will evaluate and compare the quotations (the gross amount i.e. inclusive of all taxes, other charges etc.) determined to be

substantially responsive i.e. which- (a) meet the qualification criteria specified in the tender, (b) Are properly signed, and (C) Conform to the terms and conditions, specifications without deviations.

17. Rates should be quoted strictly as per the tender specifications and should be valid for a period **August 2016 – August 2017** and any deviation from specification shall not be considered at all.

18. Total Order value for office/classroom furniture will be approx. 16 to 20 Laks, which may be more/less as per requirement. Number of a particular Item (s) in a single purchase order may be any Number, based on requirement.

19. Total initial order Value for Hostel Furniture will be approx. 26 lakhs to 28 lakhs, which may be more as per future requirement. Number of a particular Item (s) in a single purchase order may be any Numbers, based on requirement.

20. Only one best quality item (according to our specification) should be quoted against each item. On no account should different qualities e.g. A, B, & C of items be quoted. Those items that have been quoted as per different qualities (In contravention to the specifications) will not be considered at all and will be summarily rejected.

21. Based on our specifications, image/drawing of each item to be provided and Model No. (if applicable) and Brand must be clearly mentioned in the quotation, without which quotation will not be considered.

22. Generally, the date of delivery for supply of the **Furniture items** will be 30 to 45 days from the date of issue of the supply order but in emergency the same can be reduced up to 7 to 15 days depending upon the situation/requirement.

23. If the delivery is not affected on due date, the Director, IEST Shibpur, Howrah will have the right to impose penalty as under:

A) First extension for month or part thereof _____ @2% of the value of supply orders.

B) Second extension for an additional month _____ @ 3% of the value of supply order of part thereof.

C) In case of non-supply _____ @ 7.5% of the value of supply order. Or

D) In case of default institute will have the right to procure the ordered item from open market /another party at their own risk and expenses under risk purchase clause.

24. In case of non supply of material within the due date i.e. within the date of delivery, the Director, IEST Shibpur will have the right to impose penalty like forfeiture of performance security and removal of the name from the list of the vendor and resort to risk purchase in full or part thereof at his/her discretion, his/her decision shall be final and bind.

25. The IESTS authority reserves the right to accept or reject any quotation and to cancel the bidding process and reject all quotations at any stage prior to the award of contract without assigning any reason whatsoever.

26. **Last date of submission of bid is 16th August 2016 upto 5.00 p.m.**

Tender received late will not be accepted under any circumstances.

I/We accept the terms and conditions.

(Signature of Bidders with date and seal)

Tender is to be submitted To – Prof. Sudipta Mukhopadhaya

Professor in Charge – furniture

Dept. of Mining Engineering,

IEST, Shibpur, P.O. Botanic Garden, Howrah,

West Bengal, India, PIN-711103

Section2: (A)Technical Specification of the Office Furniture items:

1. EXECUTIVE REVOLVING CHAIR (Low back and push back with castors)

Brand : Godrej/Bombay Safe/Wipro

Deetails specification:

□□**SEAT/BACK:** -The seat and back shall be made up of 12 mm thick hot pressed upholstered with fabric and molded polyurethane foam, The back form shall be designed with contoured lumbar support for extra comfort.

□□**FOAM SEAT:** - 500 mm width x 470 mm depth x 50 thick.

□□**LOW BACK:** - 425mm width x 450 mm high x 40 mm thick

□□□**SYNCHRO TILTING MECHANISM:-**

A full 360 swivel mechanism to allow fluid lateral movement,

□□Mechanism undergoes a tilt Mechanism Cyclic Test 45 kg load on seat and back pulled backward with a load of 37 kg for 120000 cycles.

□□□**ARMRESTS:-**The one piece armrests shall be made of black integral skin polyurethane with 75-85 shore hardness and reinforced as& when requiredwith M.S insert. The armrests shall be scratch and weather resistant.

□□**GASLIFT:-**The gas lift shall be maintenance free, environment-friendly, chrome-free cylinder tube fixed in a M.S black powder coated outer central column tube 38 mm dia and 2 mm thick. It shall have 100 mm stroke length and gas pressure of 300N force. It shall undergo impact test.

□□**PEDESTAL ASSY:-**The pedestal is made of by MS Powder coated. M.S castor pin shall be press-fitted into each prong for holding the castors. The pedestal shall be 600 mm pitch-centre dia.

☐☐ **TWIN WHEEL CASTORS:** - The twin wheel castors shall be injection molded in black Nylon.

☐☐ **FABRIC:-** Shall contain good quality upholstery or leatherette.

Warranty: Minimum 1 year from the date of supply.

2. CHAIR EXECUTIVE REVOLVING- (high back and push back with castor)

Brand : Godrej/Bombay Safe/Wipro

Deetails specification:

SEAT/BACK: - The seat and back shall be made up of 12 mm thick hot pressed plywood upholstered with fabric and molded polyurethane foam, The back form shall be designed with contoured lumbar support for extra comfort.

FOAM SEAT: - 510 width x 470 mm depth x 50 mm thick

HIGH BACK: - 480 mm width x 680 mm high x 40 mm thick

SYNCHRO TILTING

A full 360 swivel mechanism to allow fluid lateral movement.

Chair should have better lumbar support.

ARMRESTS :- (fixed) The one piece arm rests shall be made of black integral skin polyurethane with 75-85 shore "A" hardness and reinforced with M.S insert. The arm rests shall be scratch and weather resistant.

GAS LIFT: -The gas lift is a maintenance free, environment-friendly, chrome-free cylinder tube shall be fixed in a M.S black powder coated outer central column tube 38 mm dia. and 2 mm thick. It shall have 100 mm stroke length and gas pressure of 300N force. It shall undergo impact test as per BIFMA standards.

PEDESTAL ASSY: -The pedestal is made of by MS Powder coated. M.S castor pin shall be press-fitted into each prong for holding the castors. The pedestal shall be 600 mm pitch-centre dia.

TWIN WHEEL CASTORS: - The twin wheel castors shall be of injection molded in black Nylon

FABRIC:- Shall contain the following material in various colors') Acrylic b) polyester

c) Leatherette

TELESCOPIC BELLOW ASSEMBLY: -The bellow shall be 3 piece telescopic type and injection molded in black polypropylene.

POWDER COATING: - All steel components shall be Epoxy Polyester powder coated with the following specifications:- Dry film thickness more than 45 microns. Salt spray test to withstand more than 1000 hours. Adhesion as per DIN 53152 standards Pencil scratch hardness more than 2 H

Warranty: Minimum 1 year from the date of supply.

3. Steel Office Almirah (large)

Brand : Godrej/Bombay Safe/Wipro

Deetails specification:

Size of the almirah must be 1980mm(H) x 915mm(W) x 480mm(D) [78"x36"x19"] having four shelves making five compartments without locker. Doors of almirah must be made of 1mm thick CRCA sheet providing 6 lever good quality locks, Body of the almirah must be made of 1mm (20gauge) thick CRCA steel sheet.It should be mutli welded with co2/tig welding.

All steel parts shall be pretreated for nine stage anti- corrosion treatment followed by powder coating of thickness 50-60 microns complete.

Warranty: Minimum 1 year from the date of supply.

4. Steel Office Almirah (large) with one locker

Brand : Godrej/Bombay Safe/Wipro

Deetails specification:

Size of the almirah must be 1980mm(H) x 915mm(W) x 480mm(D) [78"x36"x19"] having four shelves making five compartments. With one locker. Doors of almirah must be made of 1mm thick CRCA sheet providing 6 lever good quality locks, Body of the almirah must be made of 1mm (20gauge) thick CRCA steel sheet.It should be mutli welded with co2/tig welding.

All steel parts shall be pretreated for nine stage anti- corrosion treatment followed by powder coating of thickness 50-60 microns complete.

Warranty: Minimum 1 year from the date of supply.

5. Glass door Almirah

Brand : Godrej/Bombay Safe/Wipro

Deetails specification:

Almirah must be of overall size 1980mm(H) 15mm(W)x480mm(D) (78"x36"x19") having four adjustable shelves making five compartments. Door and body must be made of 1mm (20gauge) thick metal CRCA sheet doors must be fitted with 5mm transparent glass for clear vision, providing three way 6 lever locking device.

Warranty: Minimum 1 year from the date of supply.

6. Steel bookshelf

Brand : Godrej/Bombay Safe/Wipro

Deetails specification:

Size of the bookshelf must be 1675mm(H)x 840mm(W)x 305mm(D) [66"x33"x12"] or 1675mm(H)x 840mm(W)x 380mm(D) [66"x33"x15"] with four shutters made of 1mm (20 gauge) thick metal CRCA sheet fitted with transparent 5mm glass.

Shutters must slide on ball bearings for smooth movement and easy handling. Body of the bookshelf must be made of 1mm (20 gauge).

Warranty: Minimum 1 year from the date of supply.

7. Steel Office Table

Brand : Godrej/Bombay Safe/Wipro

Deetails specification:

Table must be fitted with a three drawer box on the right hand side of thickness 0.8mm (body) and 0.8mm (drawers). Drawers must slide on solid roller suspension for smooth movement and load bearing capacity. Frame of the table must be of 1 mm (20 gauges). Legs of the table must be made of 1"x1" square pipe of 16 gauges. Table shall be pTop shall be made of 25 mm thick superior quality pre laminated particle board of Grade II Type II conforming to IS: 12823. The edges of the table shall be banded with PVC strip 2 mm thick using hot melt glue under heat and pressure. The table top shall be supported by 1 mm thick M.S „C“ frame stiffener of size 24.2 mm (W) x 38 mm (H).

Sizes: - a) 48" (W) x24" (D) x30" (H)

Warranty: Minimum 1 year from the date of supply.

8. Steel Office Table

Brand : Godrej/Bombay Safe/Wipro

Deetails specification:

Having same above specification with a three drawers in one side & the other side will be one full cup board. **(i) without front cover; (ii) with front cover**

Sizes: a) 54" (W) X 30" (D) X 30" (H) , (b) 60" X 36" X 30" & (c) 72"(W) x 36"x 30"

Warranty: Minimum 1 year from the date of supply.

9. Visitor/ Office Chair with arm and without arm.

Brand : Godrej/Bombay Safe/Wipro

Deetails specification:

A wide variety of fabrics upholstered for the chair of our choice having high density foam in seat & back. Cantilevered type frame that is reinforced at the bends to give a spring back effect. For extra strength pipe used in CRCA 14 Swg thick round MS pipe finished with zinc phosphate for antirust treatment & powder coated oven baked finished having twin MS round pipe arm rest.

Size: Seat (W) 21" (D) 18" & seat height 18". Back (H) 12" (W) 18".

Warranty: Minimum 1 year from the date of supply.

10. "L" Shaped Modular Office Table

Brand : Godrej/Bombay Safe/Wipro

Deetails specification:

Size for Front Desk 1500mm (L) X 750mm (D)x 750mm (Ht) in prescribed position and Size for Side Unit 900 mm x 450 mm x 750 mm(Ht) with 1 no 3 Drawer Pedestal unit of Size 450mm X 515mm X 725mm (Ht), Metal key board tray and Metal CPU Trolley. The table top and Side Unit Top will be made of 25mm thick plain particle board as per IS 3087 covered with 0.6mm thick post formed laminate with both side full round edge profile. The back side of table top and Side Unit Top will be pasted with 0.8 mm thick balancing laminate. The side panel and modesty panel will be made of 25mm and 18mm thick CNC processed curved profile .All exposed edges shall be lipped with minimum 1mm thick PVCedge banding. The outer structure of Pedestal Unit shall be made up of 18mm thick pre-laminated particle board conforming to IS 12823 and the top panel shall be made of 25 mm thick full round post form laminated particle board conforming to IS 3087. The back panel of pedestal unit shall be made up of 9 mm thick pre-laminated particle board (OSL). All edges shall be lipped with 2 mm PVC edge band. Three Nos. powder coated metal drawer (Hettich make or equivalent) with sliding channels will be provided with 9mm thick pre-laminated particle board(OSL) panel as base of each drawer. The unit is to be provided with common single point locking arrangement for all the drawers. Drawers shall be provided with recessed anodized aluminum handles.

Warranty: Minimum 1 year from the date of supply.

11. Computer Table

Brand : Godrej/Bombay Safe/Wipro

Deetails specification:

Size of 1200mm (L) X 580mm (D) X 750mm (Ht). Table top will be made of 25mm thick pre-laminated particle board. The table consist of 2 No Drawer Unit (Hanging Type) Drawer of 450mm width and 450 depth in one side, 1 no Pre-Laminated keyboard tray in the middle and on the other side 1 no. shelve making two compartment for keeping CPU & Stationary .The gable ends/side panel & modesty will of 25 / 18mm all complete. All exposed edges shall be lipped with minimum 1mm thick PVC edge banding. The table consists of twin wheel castors.

Warranty: Minimum 1 year from the date of supply.

12. Executive ModularTable

Brand : Godrej/Bombay Safe/Wipro

Deatails specification:

Size for Front Desk 1800mm (L) X 900mm (D)x 750mm (Ht) in prescribed position with 2 no 3 Drawer Pedestal unit of Size 450mm X 515mm X 725mm (Ht), Wooden key board tray and Metal CPU Trolley. The table top and will be made of 25mm thick plain particle board as per IS 3087 covered with 0.6mm thick post formed laminate with both side full round edge profile. The back side of table top and Side Unit Top will be pasted with 0.8 mm thick balancing laminate. The side panel and modesty panel will be made of 25mm and 18mm thick CNC processed curved profile .All exposed edges shall be lipped with minimum 1mm thick PVC edge banding. The outer structure of Pedestal Unit shall be made up of 18mm thick pre-laminated particle board conforming to IS 12823 and the top panel shall be made of 25 mm thick full round post form laminated particle board conforming to IS 3087. The back panel of pedestal unit shall be made up of 9 mm thick pre-laminated particle board (OSL). All edges shall be lipped with 2 mm PVC edge band. Three Nos. powder coated metal drawer (Hettich make or equivalent) with sliding channels will be provided with 9mm thick pre-laminated particle board(OSL) panel as base of each drawer. The unit is to be provided with common single point locking arrangement for all the drawers. Drawers shall be provided with recessed anodized aluminum handles.

Warranty: Minimum 1 year from the date of supply.

13. Office Table (Modular)

Brand : Godrej/Bombay Safe/Wipro

Deatails specification:

Size for Desk 1200mm (L) X 600mm (D)x 750mm (Ht) in prescribed position with 1 no 3 Drawer Pedestal unit of Size 450mm X 515mm X 725mm (Ht). The table top and will be made of 25mm thick plain particle board as per IS 3087

covered with 0.6mm thick post formed laminate with both side full round edge profile. The back side of table top and Side Unit Top will be pasted with 0.8 mm thick balancing laminate. The side panel and modesty panel will be made of 25mm and 18mm thick CNC processed curved profile .All exposed edges shall be lipped with minimum 1mm thick PVC edge banding. The outer structure of Pedestal Unit shall be made up of 18mm thick pre-laminated particle board conforming to IS 12823 and the top panel shall be made of 25 mm thick full round post form laminated particle board conforming to IS 3087. The back panel of pedestal unit shall be made up of 9 mm thick pre-laminated particle board (OSL). All edges shall be lipped with 2 mm PVC edge band. Three Nos. powder coated metal drawer (Hettich make or equivalent) with sliding channels will be provided with 9mm thick pre-laminated particle board(OSL) panel as base of each drawer. The unit is to be provided with common single point locking arrangement for all the drawers. Drawers shall be provided with recessed anodized aluminum handles.

Warranty: Minimum 1 year from the date of supply.

14. Office Table (Modular)

Brand : Godrej/Bombay Safe/Wipro

Deatails specification:

Size for Desk 1500mm (L) X 750mm (D)x 750mm (Ht) in prescribed position with 1 no 3 Drawer Pedestal unit of Size 450mm X 515mm X 725mm (Ht). The table top and will be made of 25mm thick plain particle board as per IS 3087 covered with 0.6mm thick post formed laminate with both side full round edge profile. The back side of table top and Side Unit Top will be pasted with 0.8 mm thick balancing laminate. The side panel and modesty panel will be made of 25mm and 18mm thick CNC processed curved profile .All exposed edges shall be lipped with minimum 1mm thick PVC edge banding. The outer structure of Pedestal Unit shall be made up of 18mm thick pre-laminated particle board conforming to IS 12823 and the top panel shall be made of 25 mm thick full round post form laminated particle board conforming to IS 3087. The back panel of pedestal unit shall be made up of 9 mm thick pre-laminated particle board (OSL). All edges shall be lipped with 2 mm PVC edge band. Three Nos. powder coated metal drawer (Hettich make or equivalent) with sliding channels will be provided with 9mm thick pre-laminated particle board(OSL) panel as base of each drawer. The unit is to be provided with common single point locking arrangement for all the drawers. Drawers shall be provided with recessed anodized aluminum handles.

Warranty: Minimum 1 year from the date of supply.

15. Twin Seater Bench cum Desk

Brand : Godrej/Bombay Safe/Wipro

Deatails specification:

Suitable for all types of educational institutions

Sturdy and long lasting student desking system

Durable 25 mm Pre laminated MDF top, seat & back with rounded edges 2mm PVC edge.

Storage option-shelf/hanging clip on both sides.

18 mm Pre laminated MDF board shelf with 2 mm thick PVC lipping and cladding of 1 mm thick CRCA steel sheet.

Frame structure to be made of 25 X 25 X 1.2 mm thick CRCA sq. pipe.

50 micron thick Epoxy powder coated paint finish of desired color.

(i) Size: 1200 (L) X 900 (D) X 720-750mm (H)

(ii) Only Desksize: (L) 1200 X (D) 400 X (H) 750 mm.

Warranty: Minimum 1 year from the date of supply.

16. VERTICAL FILING CABINET (VFC) of size 54" H x19" W x 27" D having 4 drawers

Brand : Godrej/Bombay Safe/Wipro

Details specification:

- Multi bend construction with press fit fastener free design.
- Roll formed side back side for drawers.
- 10 lever cam lock.
- Thickness of the CRCA Steel sheet will be 1 mm.
- Drawer with ball slides anti tilt and anti rebound mechanism.

Anti corrosion treated components and oven-baked powder coating process.

Warranty: Minimum 1 year from the date of supply.

17. "S" type office Chair

Brand : Godrej/Bombay Safe/Wipro

Details specification:

SEAT / BACK : The seat and back are made up of 1.2cm thick hot pressed plywood, upholstered with fabric and molded Polyurethane foam with PVC lipping all around. The back foam is designed with contoured lumbar support for extra comfort. The seat and back undergo a back pull test (45kg. Load on seat and back

pulled forward and backward with a load of 34kg. For 1, 20,000 cycles) and Impact test (57kg. Load dropped for 1, 00,000 cycles).

SEAT SIZE: 45.0 cm (W) x 42.5cm (D)

BACK SIZE: 45.0CM (W) x 69.0 cm (H)

POLYURETHANE FOAM: The polyurethane foam is 5.0 cm and molded with density = 50-55 kg/m³ and Hardness = 20 + 2 kg. On Hampden machine at 25% compression.

SEAT FOAM SIZE: 49.0CM (W) x 45.0cm (D)

BACK FOAM SIZE: 49.0cm(W) X 70.0 cm (H)

ARMRESTS: The one-piece armrests are made of black integral skin polyurethane with 75-85 Shore. The armrests are scratch and weather resistant (soft PU).

TUBULAR FRAME:The tubular frame is cantilever type and made of dia. 2.5cm x 14BG M.S.E.R.W. tube as per IS : 1161 and powder coated.

POWDER COATING: All steel components are Epoxy Polyester Powder Coated with the following specifications:

Dry film thickness more than 45 microns.

Salt spray test to withstand more than 1000 hours

Warranty: Minimum 1 year from the date of supply.

18. Cushioned Chair (Brand Godrej./ Wipro) without arm rest

Specification for cushioned chair:

1. Seat/Back assembly: The seat and back are made from 1.0 cm thk. hot pressed water resistant, commercial plywood upholstered with P.U. foam and fabric.

Back size : 42.0cm(W) x 26.5 cm (H), Seat Size : 42.0 cm (W) x 42.0 cm (D)

2. Polyurethane Foam: The Polyurethane foam is moulded with density= 45+/-2 Kg/m and hardness = 20 +/-2 kg on Hampden machine at 25 % compression.
3. Understructure Assembly: The assembly is a mainframe made of dia. 2.54 cm. (1") x 14 BG M.S. E. R. W. tube and a welded leg tube made of dia. 2.54 cm. (1") x 18 BG M.S. E. R. W. tube to the form the complete assembly which is black powder coated.
4. Diagram of chair is as follows:

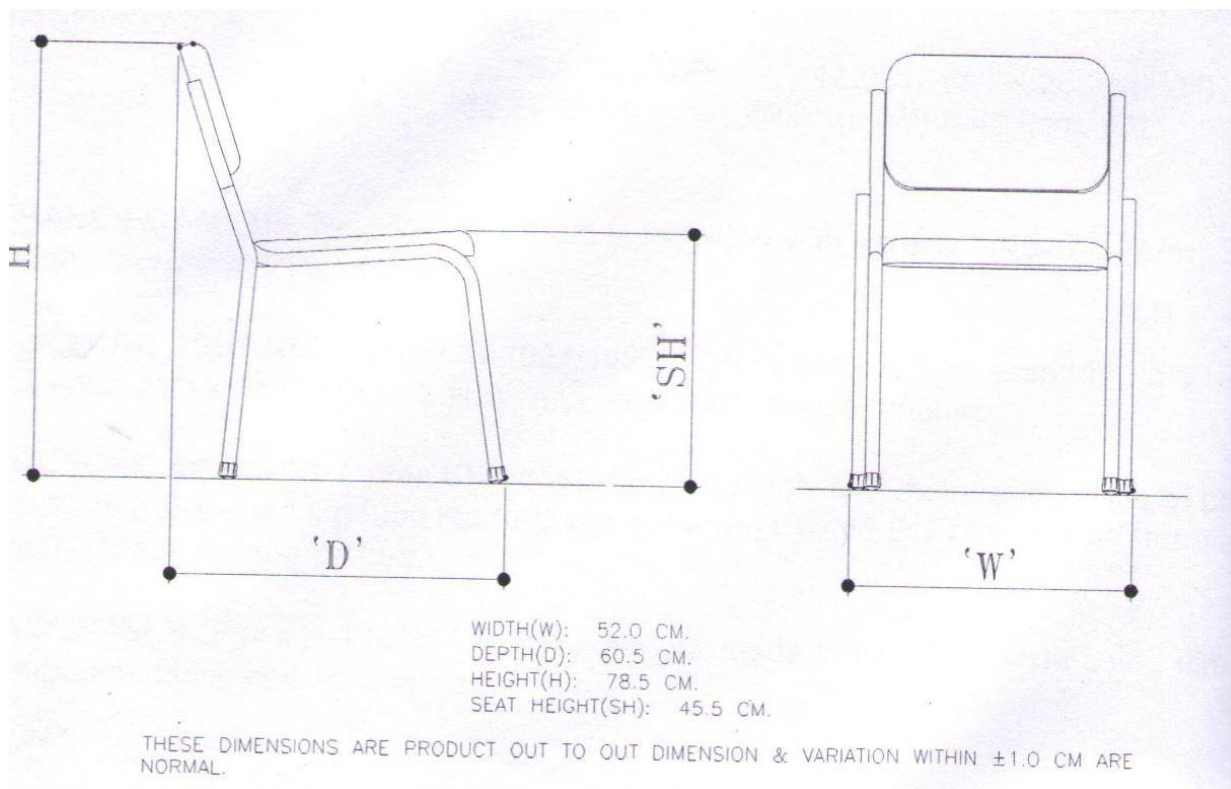

Warranty: Minimum 1 year from the date of supply.

19. Cushioned Chair (Brand Godrej./ Wipro)

Specification for cushioned chair:

1. Seat/Back assembly: The seat and back are made from 1.0 cm thk. hot pressed water resistant, commercial plywood upholstered with P.U. foam and fabric.

Back size : 42.0cm(W) x 26.5 cm (H), Seat Size : 42.0 cm (W) x 42.0 cm (D)

2. Polyurethane Foam: The Polyurethane foam is moulded with density= 45+/-2 Kg/m and hardness = 20 +/-2 kg on Hampden machine at 25 % compression.

3. Understructure Assembly : The Understructure Assembly is a cantilever type mainframe made of dia. 2.54cm(1") x 14 BG M.S. E.R.W. tube and black powder coated.
4. Armrest Assembly: The armrests are made in twin tube form using dia. 1.58cm(⁵/₈ inch) x 16 BG M.S. E.R.W. tube and black powder coated
5. Diagram of chair is as follows:

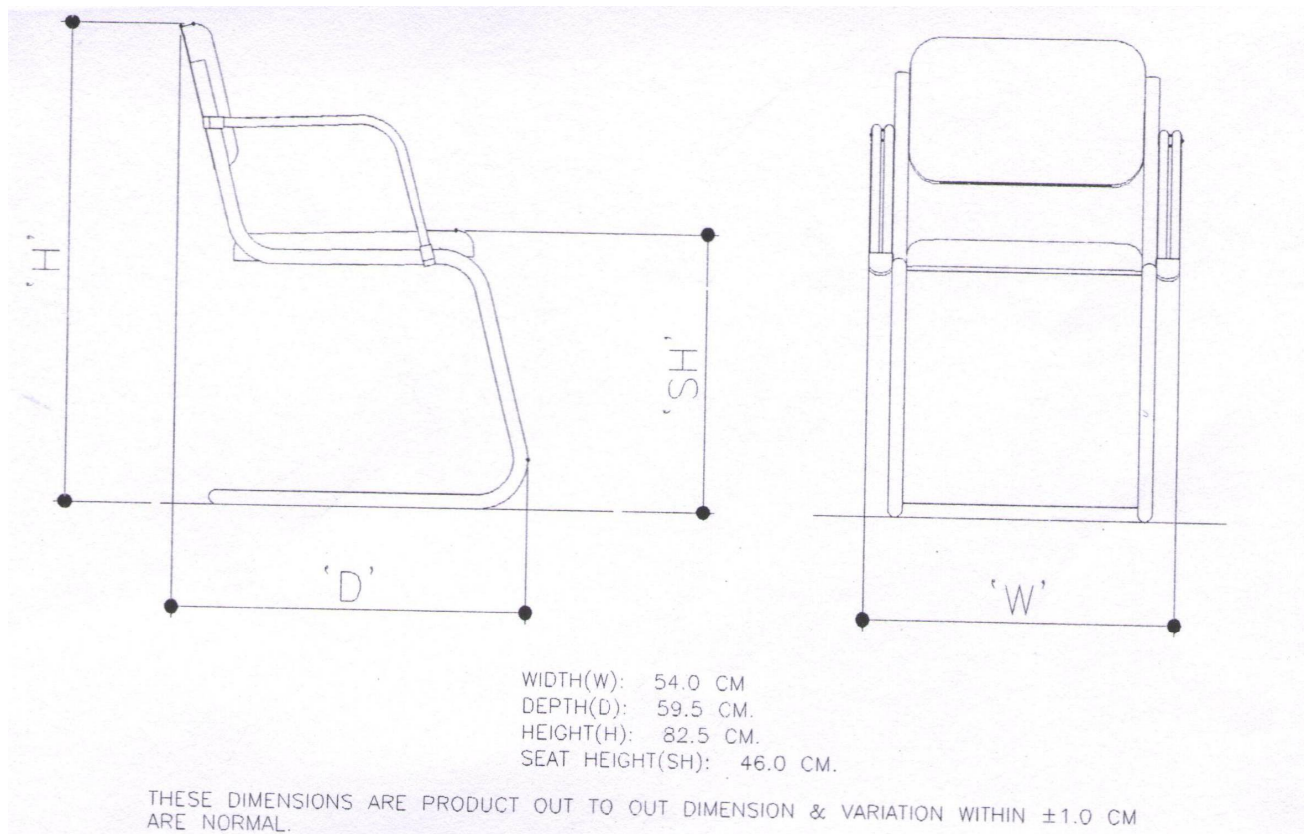

Warranty: Minimum 1 year from the date of supply.

20. Cushioned Chair (Brand Godrej./ Wipro)

Specification for cushioned chair:

1. Seat/Back assembly: The seat and back are made from 1.0 cm thk. hot pressed water resistant, commercial plywood upholstered with P.U. foam and fabric.
Back size : 42.0cm(W) x 26.5 cm (H), Seat Size : 42.0 cm (W) x 42.0 cm (D)
2. Polyurethane Foam: The Polyurethane foam is moulded with density= 45+/-2 Kg/m and hardness = 20 +/-2 kg on Hampden machine at 25 % compression.

3. Understructure Assembly : The Understructure Assembly is a cantilever type mainframe made of dia. 2.54cm(1") x 14 BG M.S. E.R.W. tube and black powder coated.
4. Diagram of chair is as follows:

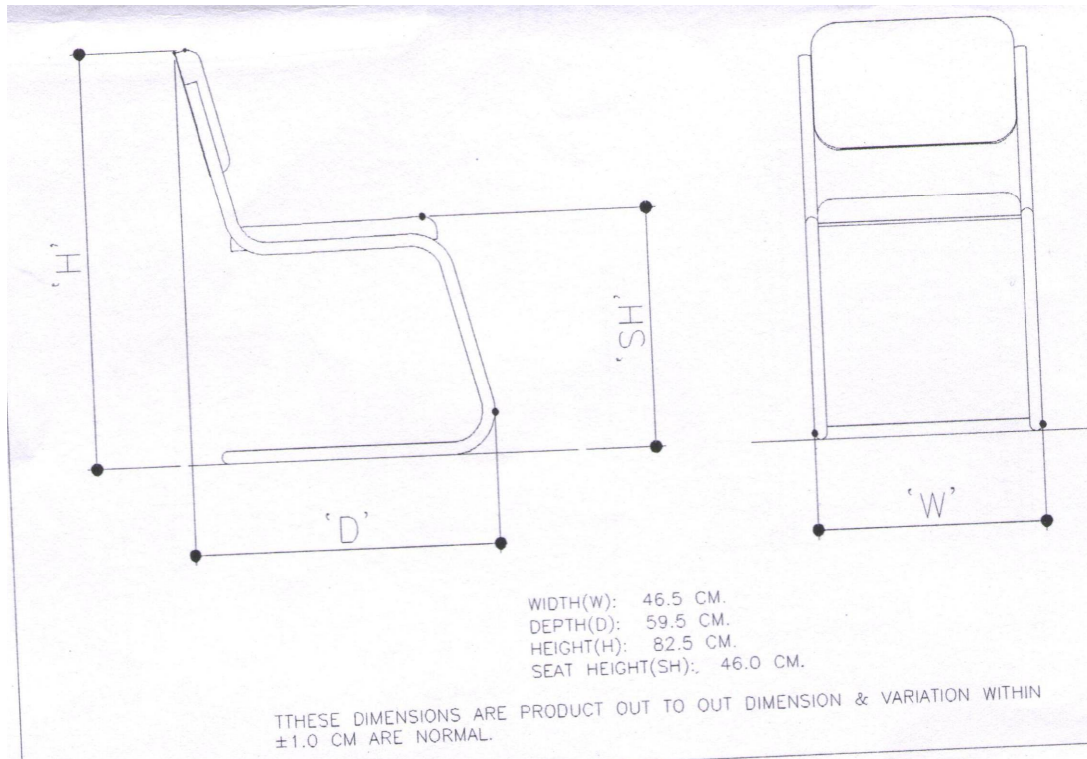

Warranty: Minimum 1 year from the date of supply

21. Mid back chair for Use at Office (Brand Godrej./ Wipro)

Seat and back made up with 1.2 cm thick hot pressed plywood & upholstered with fabric & moulded polyurethane foam with PVC lipping. Dimension of back is 410mm x 460mm. Dimension of seat is 430mm x 410mm. Armrests is made up with black integral polyurethane with 50-70 shore A hardness with MS insert. It should have features like 360° revolving, upright position locking, tilt tension adjustment. The below is 3 piece telescopic type and injection moulded. The pedestal is fabricated with 0.2 cm thick HR sheet, powder coated, and fitted with injection moulded black polypropelene hub cap and 5 nos. twin wheels castor made up with black nylon.

Warranty: Minimum 1 year from the date of supply.

22. Revolving Chair (Brand Bombay Safe/Wipro)

Specification details:

Size:

Seat: 17'' X 17'' X 2'' (Thick)

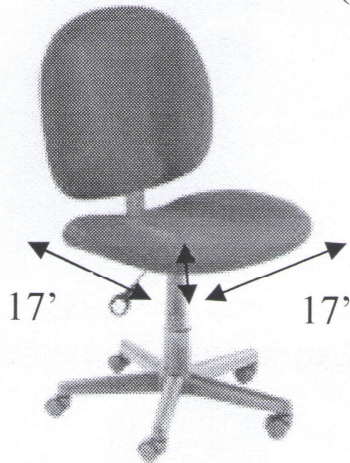

Backrest: 16'' X 20'' (Height) X 1.5'' (Thick)

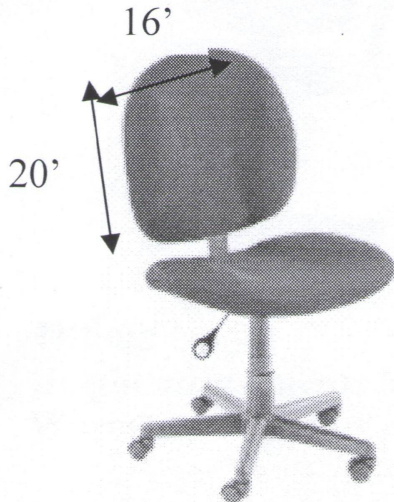

Material: High density rubber foam seat and backrest covered by cloth.

Height: 18''-22'' (Base to seat). **Height Adjustment:** Manual



Height Adjustment: Manual [using screw but No hydraulic lever]

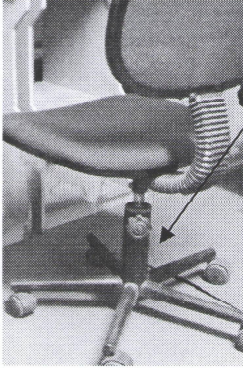

Base: Steel leg with castor (number: 5)

Armrest: PU rubber padded armrest



Tilting: No

Height adjustment: Manual

Warranty: Minimum 2 years from the date of supply.

23. REVOLVING CHAIRS (Model Godrej./ Wipro)

- SEAT /BACK ASSEMBLY: The seat and back are made from 1.2 +/- 0.1 cm. thk hot pressed plywood measured as per QA method described in OCP-QLTA-P14-18 and upholstered with fabric and moulded Polyurethane foam together with seat and back covers. The back foam is designed with contoured lumber support for extra comfort.

Seat Size : 45cm (W) x 42 cm (D)

Back Size : 40cm (W) x 47 cm (H)

- Seat and back covers : Injection moulded in black Co-polymer polypropylene.
- High Resilience (HR) Polyurethane foam: The HR polyurethane foam is moulded with density = 45 +/- 2 kg/m³ and hardness load 16+/-2 kgf as per IS 7888 for 25% compression.
- Permanent Contact Mechanism: The permanent contact mechanism is designed with the following features:

360° revolving type.

14°=/- 2° maximum back tilt only.

Upright position locking

Tilt Tension adjustment.

- Pneumatic Height Adjustment : The Pneumatic Height Adjustment has an adjustment stroke of 11+/-0.3 cm.
- Telescopic below assembly: The below is 3 piece telescopic type and injection moulded in black polypropylene.
- Pedestal Assembly: The pedestal is injection moulded in black 30 % glass filled Nylon and fitted with 5 Nos. Twin wheel castors. The pedestal is 62+/-0.5 cm pitch-centre dia. (72+/-1 cm with castors)
- Twin wheel castors: are injection moulded in black nylon.
- Diagram of chair is as follows:

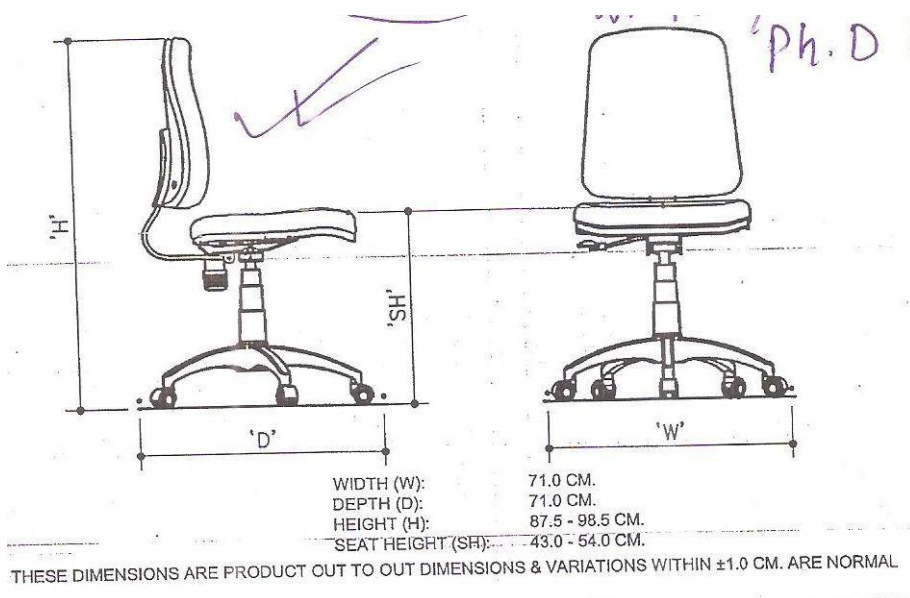

Warrenty : Minimum 2 Years

24. REVOLVING CHAIR WITH ARMREST (Model Godrej./ Wipro) :

Technical Specification :Same as item 23 with only addition:

Armrest Assembly: the one piece armrests are injection moulded from black Nylon. The armrests are fitted to the seat with armrest connecting brackets made of 0.5 +/-0 .05 cm thk. HR steel.

Warrenty : Minimum 2 Years

Section2(B): **Technical Specification of the Hostel Furniture items**

1H. STUDY TABLE FOR HOSTEL (900 x 600 x 750mm – Ht.)

Brand : Godrej/Bombay Safe/Wipro

Deetails specification:

☐☐Top shall be made of 25 mm thick superior quality pre laminated particle board of Grade II Type II conforming to IS : 12823 . The edges of the table shall be banded with PVC strip 2 mm thick using hot melt glue under heat and pressure.

The table top shall be supported by 1 mm thick M.S „C☐ frame stiffener of size 24.2 mm (W) x 38 mm (H).

☐☐The table shall have 4 legs made of Electric Resistant Welded prime quality CRCA steel square tubular frame of 25.4 mm size and of 1.4mm thickness. The base of legs of the table shall be covered with plastic caps.

☐☐The table shall have one no drawer Unit with necessary locking arrangement. The drawer unit shall be of overall size 355 mm (W) x 560mm (D) x 430mm (H). The drawer unit shall be made of 0.9 mm thick CRCA sheet and drawer trays shall be made of 0.8 mm thick CRCA sheet. The drawer shall glide on double slided telescopic channel and shall have a multipurpose steel lock with handles built in place. The drawer unit shall have a mechanism to ensure only one drawer opens at a time. The drawer shall be fitted to „C☐ frame by machine screws. Joints shall be interlocked and welded to render flawless appearance. All steel parts shall be pretreated for nine stage anti- corrosion treatment followed by powder coating of thickness 50-60 microns complete. The steel tube shall conform to IS: 3601-1984, IS: 7138 -1973 and IS: 4923- 1985.

Warrenty: 3 years from the date of supply.

2H. Almirah (Small).

Brand : Godrej/Bombay Safe/Wipro

Deetails specification:

Size of the almirah must be 1250mm(H) x 750mm(W) x 430mm(D) [50"x30"x17"] having three shelves making four compartments without locker. Doors of almirah must be made of 1mm thick CRCA sheet with necessary locking arrangement

(arrangement for PAD Lock), Body of the almirah must be made of 1mm (20gauge) thick CRCA steel sheet. It should be multi welded with CO₂/TIG welding.

All steel parts shall be pretreated for nine stage anti-corrosion treatment followed by powder coating of thickness 50-60 microns complete.

Warranty: 3 years from the date of supply.

3H. Steel cots with water proof and termite proof 3/4 inch plywood tops

Brand : Godrej/Bombay Safe/Wipro

Details specification:

Overall Bed Size: 1910 mm (Length) X 965 mm (Width) X 530 mm (Head Rest Height) X 530mm (Leg Side Height) & 380 mm (Overall) Height of the Bed with main frame structure made of 50 mm X 25 mm X 1.6 mm thick CRC hollow rectangular MS pipe with 4 (four extra middle support of 25 mm X 25 mm X 1.6 mm thick CRC square MS pipe at equal distance. The four legs would be made of 40 mm X 2 mm thick (one pc.) CRC round MS pipe and a MS plate (1.6 mm. thick) used for bracing at the four corner of the bed. The TOP COVER (FOR Mattress) of the bed is made of 18 mm thick ISO 9001 Grade, ISI standard, BWR ply. The (extended Height) Part of Head side should be connected with a parallel horizontal & 03nos. 18 X 1 mm thick CRC round MS pipe vertical connected (as shown in drawing). The open end of the legs would be covered by Rubber Buffer. All metal components should be treated by nine tanks process for Powder Coating paint i.e. Degreasing (1st Tank) Water rising (2nd Tank), Dipping by Acid (3rd Tank), Water rising (4th Tank), Water rising (5th Tank), Activation (6th Tank), Phosphating (7th Tank), Water rising (8th Tank) and Passivation (9th tank) respectively with non-electrolytic deep process to produce a protective oxide coating for smooth surface with matt finish anticorrosive automated powder coating paint of thickness 50-60 microns and oven backed for high resistance to scratch, chemical, thermal and mechanical stresses.

(Drawing has to be provided with quotation)

Warranty: 3 years from the date of supply.

4H. Fixed Chair

Brand : Godrej/Bombay Safe/Wipro

Details specification:

Seat, back and armrests are crafted from durable high quality hardwood which can resist for years good quality upholstery & high density foam used for seat and back.

The square/ round pipes would be of 25mm/ 1" dia of **(16 SWG)** thickness made from prime CRCA Steel. Powder coated paint finished of 50 - 60 microns thickness.

Warrenty: 3 years from the date of supply.